



Pathogenic diversity of *Puccinia kuehnii* strains, causal agent of sugarcane leaf rust and biological control approach using biopesticides under semi-controlled conditions

KONE Klinnanga Noel¹, KOUAME Konan Didier², YAO Kouadio Jacques-Edouard³, N'GUESSAN Aya Carine¹, KASSI Koffi Fernand Jean-Martial², OUATTARA Migninlbin Marcel², KONE Daouda²

¹University Peleforo Gon Coulibaly, UFR of Biological Sciences, Departement of plant Biology, BP 1328 Korbogo, Côte d'Ivoire

²University Félix Houphouët Boigny, UFR Biosciences, UPR Plant Physiology and Pathology, 22 BP 582 Abidjan 22, Côte d'Ivoire

³University Jean Lorognon Guédé, UFR Agroforestry, UPR Plant Physiology, BP 150 Daloa, Côte d'Ivoire

Key words: Sugarcane, *Puccinia kuehnii*, Infectivity, Essential oils.

Submitted 10/09/2024, Published online on 31st October 2024 in the [Journal of Animal and Plant Sciences \(J. Anim. Plant Sci.\) ISSN 2071 – 7024](#)

1 SUMMARY

Context: In Côte d'Ivoire, sugarcane plays an important role in the economy. However, its production is constrained by biotic factors, particularly orange rust caused by *Puccinia kuehnii*. Pathogenic diversity of strains is not widely understood. Existing control methods are ineffective and limited. The aim of this study was to determine the pathogenicity of *Puccinia kuehnii* strains, and to evaluate anti-fungal activity of essential oil-based formulations against this disease. **Materials and methods:** Strains 51bB and 381Z were evaluated for infectivity by foliar spraying plants of variety SP711406 under semi-controlled conditions at the Université Félix Houphouët-Boigny in Abidjan (Côte d'Ivoire). Curative control was carried out by foliar spraying plants with formulations based on natural substances of *Ocimum gratissimum* L, *Zingiber officinale* and *Cymbopogon citratus*, at 500, 1000 and 2000ppm. **Results:** Strains 51bB and 381Z showed infection rates of 62.26 and 67.36% respectively after a four-month incubation period. Severities of 30.64% (51bB) and 30.23% (381Z) were observed. ZinC1 and ZinC2 treatments had an estimated incidence reduction rate of 64.28%. Treatments based on natural substances achieved a reduction in severity of over 50%. The CymC2 treatment was the most effective, with a reduction rate of 86.04% followed by ZinC1 with rates of over than 50%. reduction rate of incidence and severity due to the synthetic product was 50 and 48.83% respectively. **Conclusion:** *Puccinia kuehnii* strains induced orange rust disease in sugarcane. The effect of essential oil-based formulations has been proven on the disease under semi-controlled conditions.

2 INTRODUCTION

Orange rust disease of sugarcane, whose aetiological agent is the fungus *Puccinia kuehnii* (W. Krüger), is one of the most damaging diseases of sugarcane in most tropical areas (Hubert *et al.*, 2019; Mungur *et al.*, 2020). This disease was first recognised in the south-west Indian Ocean, on the islands of Réunion and Mauritius in 2018 and has since spread to several parts of the world (Comstock *et al.*, 2008). Average night-time temperatures of 20-22°C combined with high relative humidity (>90%) are the most favourable conditions for its spread (Sanjel *et al.*, 2019; Chaulagain *et al.*, 2020). In addition, the pathogen is also spread by wind and by rainwater splashing over short distances (Infante *et al.*, 2009). The disease manifests itself through a reduction in the surface area of green leaves and the net photosynthesis rate of the leaves, and affects plant growth, resulting in yield losses in sugarcane (Grimmer *et al.*, 2012). Epidemics can last several months, particularly during active plant growth (Hubert *et al.*, 2019; Mungur *et al.*, 2020). For example, the extent of sugarcane shearing loss due to rust can vary

between 30 and 50%, as recently recorded in Australia, Brazil and the United States, where varieties susceptible to orange rust have been grown on a large scale (Magarey *et al.*, 2001; Rott *et al.*, 2017). In view of the damage, Flore *et al.* (2009) proposed the use of resistant varieties for chemical rust control, while Hoy (2008) focused on cultural control. In Côte d'Ivoire, orange rust disease was found in 2009 and 2010 on the SP 71-6180 and Co 997 varieties in Zuénoula and Borotou-Koro sugar complexes (Saumtally *et al.*, 2011). However, there has been a limited number of scientific studies aimed to improve knowledge of strains and to propose control methods. This study was carried out to provide innovative solutions for controlling sugarcane orange rust disease, with a view to improving sugarcane and sugar production in sugar complexes in Côte d'Ivoire. Specifically, the aim was to: (i) Determine pathogenicity of *Puccinia kuehnii* strains under semi-controlled conditions; (ii) Evaluate antifungal activity of three biopesticides on orange rust disease caused by *Puccinia kuehnii* under semi-controlled conditions.

3 MATERIALS AND METHODS

3.1 Material

3.1.1 Study area: Trials were carried out in a greenhouse at the University Félix Houphouët-Boigny in Abidjan, Côte d'Ivoire.

3.1.2 Plant material: plant material consisted of two (02) month old plants of sugarcane variety SP711406. Twelve (12)-month-old seed cuttings of this variety were taken from an experimental plot at the University Félix Houphouët-Boigny in Abidjan.

3.1.3 Fungal isolates: Two strains of *Puccinia kuehnii* coded '381Z' and "51bB" collected from the sugar-growing sites of the Integrated Agricultural Units (UAI) of Zuénoula and Borotou-Koro in 2021 were used for pathogenicity test. These strains were isolated from symptomatic leaves of

sugarcane and were selected as the most virulent strains following laboratory tests. They were then also used for the control test and compared with untreated controls coded S0 placed under natural infection conditions.

3.1.4 Essential oils and synthetic products: Antifungal activity of *Zingiber officinale*, *Cymbopogon citratus* and *Ocimum gratissimum* L essential oils were evaluated. These essential oils were supplied by the Unité de Recherche Industrielle (URI) of the University Félix Houphouët-Boigny and used to formulate biopesticides. A synthetic product based on copper oxide was used as a positive control.

3.2 Methods

3.2.1 Evaluation of the pathogenicity of *Puccinia kuehnii* strains

3.2.1.1 Treatment and planting of sugarcane cuttings under semi-controlled conditions: Asymptomatic cuttings of sugarcane variety SP711406 of twelve (12) months aged were collected from the propagation plot. These cuttings were

washed and carefully stored in containers. Then, they were sterilised by short heat treatment in a water bath at 52°C for 30 min (Fig. 1A), according to the modified methodology of Rott *et al.* (1997). After washing, they were planted in 30 cm high bags (Fig. 1B), filled with previously sterilised soil.



Figure 1: Thermoherapy treatment (A) and planting of cuttings (B)

3.2.2 Experimental design: Trials were conducted under semi-controlled conditions in the experimental site of the University Félix Houphouët-Boigny in Abidjan. A completely randomised block design (Fisher block) with three replications was used as

experimental design. Each block consisted of 36 representative plants for each one strain. blocks and sub-blocks were spaced 50 cm apart. In each sub-block, the plants were spaced 20 cm apart (Fig. 2).

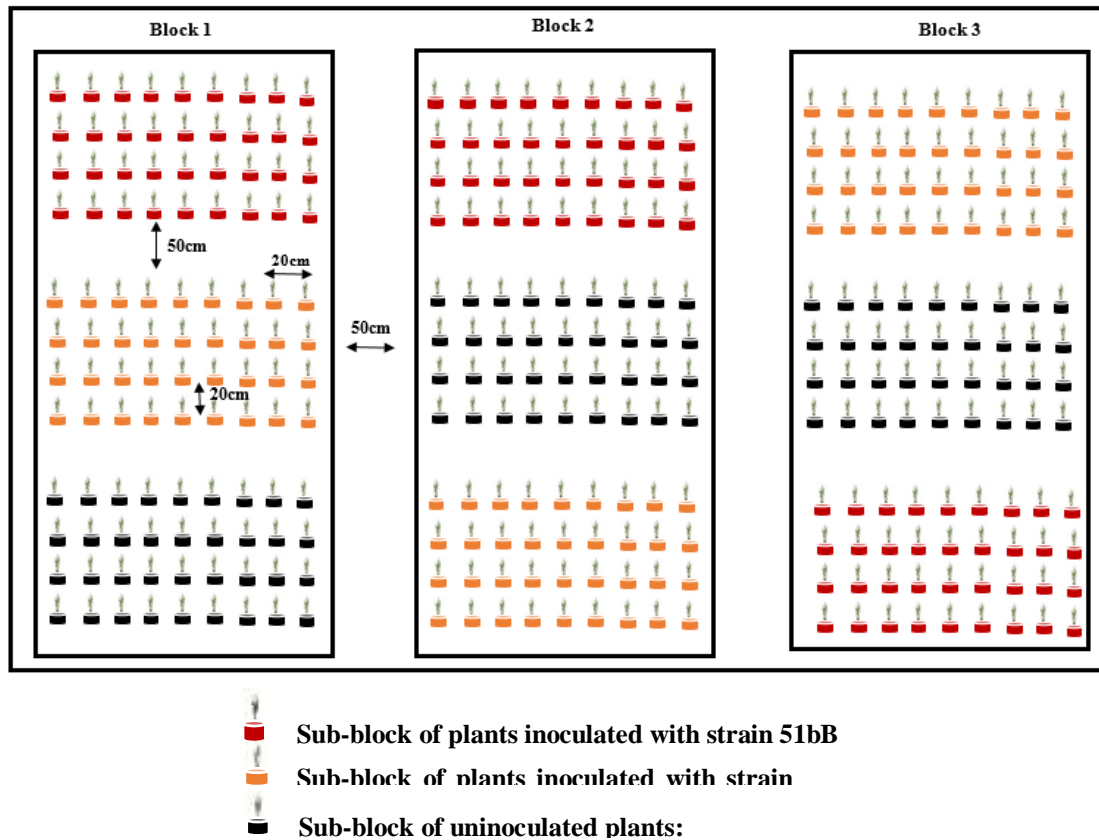

Figure 2: Experimental design for seedlings under semi-controlled conditions

3.2.3 Inoculum production and leaf inoculation: Inoculum preparation with *Puccinia kuehnii* urediniospores required a sporulation test. This test required symptomatic samples of sugarcane leaves, previously preserved, to be placed on absorbent paper in 90 mm-diameter Petri dishes. Leaves were sprayed with sterilised distilled water and incubated in the dark at 22°C for 12 hours. After incubation, urediniospores were collected using a scalpel blade and added to sterilised distilled water. resulting suspension was vortexed for one (01) minute. A drop of this suspension was then placed in the well of a Malassez haematimeter in order to estimate the number of spores. This number was adjusted to 10^4 spores/ml (Sood *et al.*, 2009) by dilution with sterilised distilled water.

Inoculation was carried out under semi-controlled conditions following Chapola *et al.* (2016) method, which involved inoculating thirty (60)-day-old plants using a hand-held sprinkler. In addition, inoculation focused on the abaxial leaf surface and continued until runoff.

3.2.4 Disease assessment: Phytosanitary assessments were focused on incubation period, severity index and sugarcane orange rust disease incidence. Severity index provides a quantitative evolution of disease attack degree. It expresses the intensity of symptoms observed on plants. Scores were assigned to symptoms observed each plant leaves according to Purdy and Dean (1981) symptom rating scale modified (Table 1). Severity index was calculated according to the following formula of Kranz J. (1988):

$$I_s (\%) = \frac{\sum X_i \cdot n_i \times 100}{NZ}$$

I_s: severity index; **X_i**: grade of disease **i**; **n_i**: number of stems with grade **X_i**;
N: total number of leaves inoculated; **Z**: highest score on the scale.

Disease infection rate or incidence is defined as the proportion of affected plants in a given population. It was calculated using the following formula:

$$\text{Infection rate}(\%) = \frac{\text{number of infected plants} \times 100}{\text{total number of plants}}$$

Table 1: Scale for rating the severity of orange rust of sugar cane (Purdy and Dean, 1981)

Scores	Percentage (%)	Characteristics
0	0	No symptoms
1	1 - 20	Slight presence of white or yellow streaks or lines on the leaf blade parallel to the veins
2	21 - 40	Average presence of striations on the leaf blade
3	41 - 60	Slightly heavy streaking on leaf blades
4	61 - 80	Strong presence of striations on the leaf blade
5	81 - 100	Average presence of striations on the leaf blade, leaves completely necrotic

3.3 Evaluation of essential oils efficacy on orange rust disease incidence and severity plants inoculation and curative treatments: inoculum production and leaf inoculation method previously used in the pathogenicity test was used. Plants were inoculated with *Puccinia kuehnii* strain 381Z spores, which had highest severity and incidence of orange rust disease. Essential oils were tested at two concentrations :1000 ppm and 2000 ppm. Treatments were carried out by foliar spraying every fortnight.

3.3.1 Experimental design: Treatments were carried out in a complete block design

(Fisher block) with three replications. Each block consisted of eight (08) sub-blocks with 15 plants spaced by 20 cm. blocks and sub-blocks were respectively separated by 50 cm and 30 cm (Fig. 3). Each sub-block measured 80 cm in length and 40 cm in width. A total of eight (08) treatments were carried out: **ZinC1:** *Zingiber officinale* at 1000 ppm ; **ZinC2:** *Zingiber officinale* at 2000 ppm ; **OciC1:** *Ocimum gratissimum* L at 1000 ppm ; **OciC2:** *Ocimum gratissimum* L at 2000 ppm ; **CymC1 :** *Cymbopogon citratus* at 1000 ppm ; **CymC2 :** *Cymbopogon citratus* at 2000 ppm ; **Cal :** Copper oxide at 5000 ppm ; **T0 :** Untreated plants.

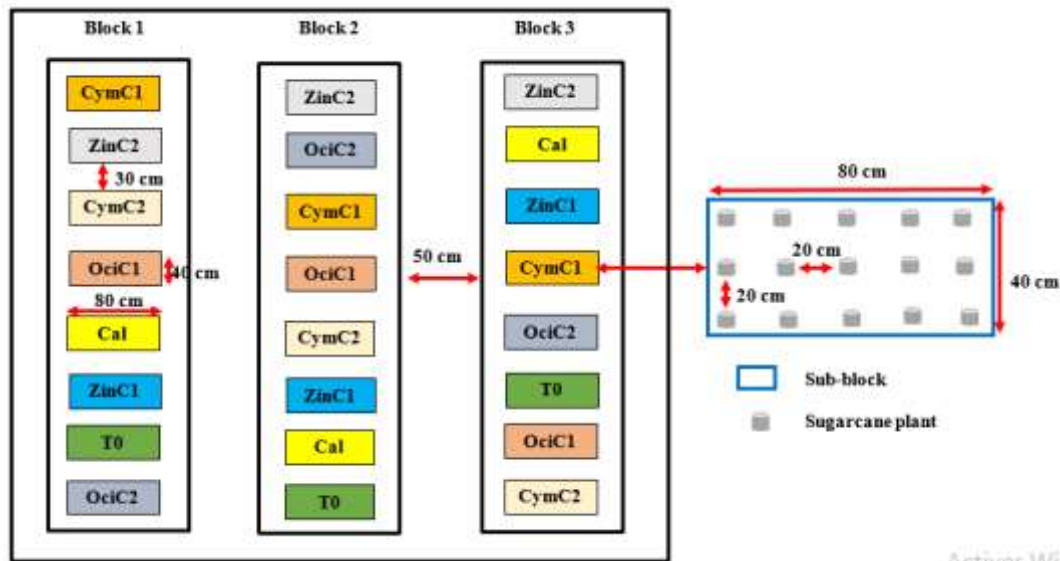

Figure 3: Experimental design for testing essential oils efficacy on orange rust in sugarcane under semi-controlled conditions.

3.3.2 Disease assessment parameters:

Orange rust disease incidence and severity index were phytopathological parameters used for assessment. They were carried out every fortnight. Each treatment was followed by an assessment on the same day. Four assessments and three treatments were carried out during this test. disease reduction rate was determined using the following formula:

$$TR(\%) = \frac{(TiTe - TiTr) \times 100}{TiTe}$$

4 RESULTS

4.1 Infection rate of orange rust disease on sugarcane plants:

Orange rust disease incidence was zero from the first to the third month after inoculation. Strain 51bB showed an increasing infection rate between months 3 and 7, ranging from 36.11 to 75%. For 381Z strain, results showed a largely increasing trend compared with the other, ranging from 50.92 to 78.70% between months 3 and 7. Control plants (S0) showed relatively low infection and growth rates for all months, ranging from 14.81 to 62.96%

TR : Reduction rate ; **TiTe** : Control infection rate ; **TiTr** : Infection rate after treatment

Statistical analysis Analyses were performed using Statistica 7.1 software. an ANOVA was performed with a 5% significance level. When a significant difference was observed, means of disease incidence and severity rates were compared with Newman-Keuls test to classify them into homogeneous groups.

(Fig. 4A). Figure 4B shows orange rust disease mean infection rate on sugarcane plants as a function of *Puccinia kuehnii* isolates. significant differences were observed between strains at 5% level according to ANOVA test. Multiple comparisons with Newman-Keuls test showed higher infection rates for strain 51bB and 381Z, with values of 62.26 and 67.36% respectively. Uninoculated plants had the lowest infection rate, estimated at 32.40%.

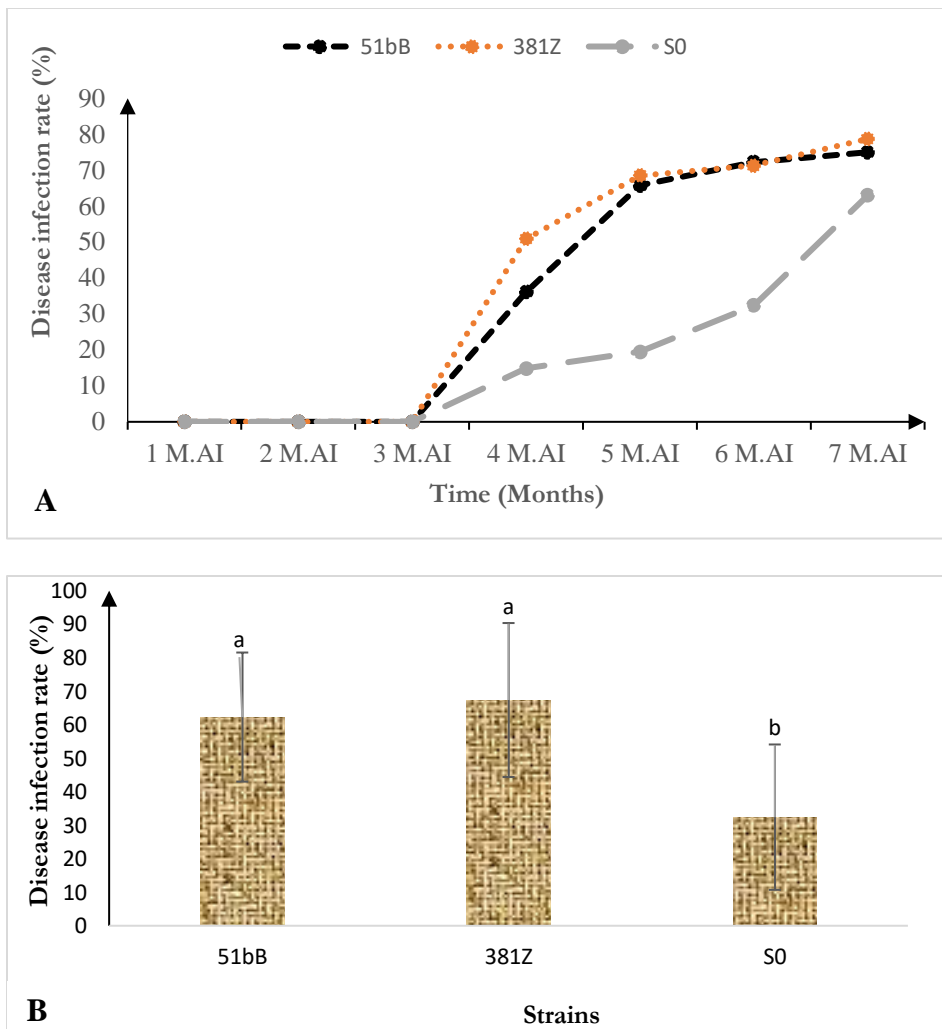

Figure 4: Incidence (A) and infection rate (B) of orange rust disease over time, by strain
M.AI: *Months After Inoculation*

4.2 Mean severity of orange rust disease on sugarcane plants: Mean severity of orange rust has increased progressively with time and strain (Fig. 5A). Evolution curve was zero from the first to the third month. From the 3rd month onwards, strain 51bB showed an increasing trend and from the 5th month onwards overcame all the other curves. It recorded a severity of 8.18% and progressed to reach a value of 36.29% at month 7. For 381Z strain,

results showed an increase in severity average from 11.57% to 35.18% between months 3 and 7. Non-inoculated plants showed a severity ranging from 3.53 to 29.44%. Results showed significant differences between strains at 5% level. Strains 51bB and 381Z induced statistically identical mean severities of orange rust disease, with 30.64 and 30.23% respectively. Non-inoculated plants (S0) showed a lower mean severity of 14.81%. (Fig. 5B).

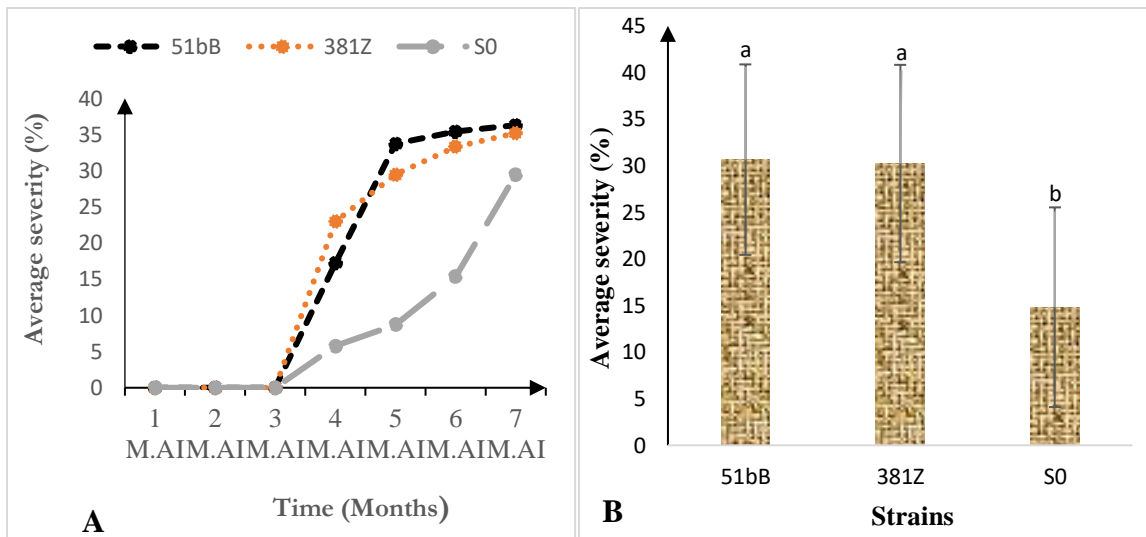

Figure 5: Evolution (A) and mean severity (B) of orange rust disease related to time and strains

M.AI: Months After Inoculation

4.3 Effect of biopesticides on orange rust disease incidence as a function of time:

Application of products by foliar spraying contributed to a significant reduction in orange rust disease levels. A different symptomatic response was observed for each product and dose tested. (Fig. 6). Before treatment (B.Tr), plants to be treated with products formulated using *Z. officinale* essential oil at a concentration of 1000 ppm (ZinC1) showed an infection rate of 60%. Fourteen (14) days after treatment (D14.Af.Tr), disease incidence decreased to 46.67%. This infection rate remained constant until twenty-eight (28) days after treatment (D28.Af.Tr). At 42 days post-treatment (D42.Af.Tr), infection rate was 33.33%. Previously treated plants which received *Z. officinale* essential oil at a concentration of 2000 ppm (ZinC2) showed an incidence of 86.67%. This value was also observed at D14.Af.Tr. However, at D28.Af.Tr, a decrease in incidence was observed with a value of 40%. This infection rate decreased to 33.33% at D42.Ap.Tr. Plants treated with OciC1 (a formulation based on the essential oil of *O. gratissimum* L at a concentration of 1000 ppm) showed an incidence of 66.67% before treatment. Two

weeks later, this infection rate remained constant after further treatment (D14.Af.Tr). However, it decreased progressively to reach a value of 46.67% at D42.Af.Tr. An infection rate of 86.67% was observed in plants treated with OciC2 (a formulation based on essential oil of *O. gratissimum* L at a concentration of 2000 ppm), before treatment. At fourteen (14) and twenty-eight (28) days after treatment, infection rates recorded were 80 and 73.33% respectively. A significant decrease was observed in infection rates at D42.Af.Tr, with an estimated value of 40%. Disease infection rates decreased from 46.67 to 40%, respectively before and fourteen (14) days after treatment, in plants treated with *C. citratus* essential oil at a concentration of 1000 ppm (CymC1). At D28.Af.Tr, an increase of 53.33% was observed in infection rate. However, at D42.Af.Tr, 50% infection rate was observed. Plants treated with CymC2 (a formulation based on *C. citratus* essential oil at a concentration of 2000 ppm) were all infected by orange rust disease. After the first treatment (D14.Af.Tr), there was a little decrease in disease incidence, reaching a value of 93.33%. However, a sharp decrease was observed from D28.Af.Tr to D42.Af.Tr with a constant infection rate of

46.67%. Before plants were treated with synthetic callicopper (copper oxide), an incidence of 93.33% was observed. This incidence was reduced to 80% (D14.Af.Tr). In addition, disease infection rates decreased significantly from 66.67 to 46.67% between

D28.Af.Tr and D42.Af.Tr respectively. Untreated inoculated plants (T0) had an infection rate of 80% at the first assessment. This rate increased to 93.33% at the final evaluation.

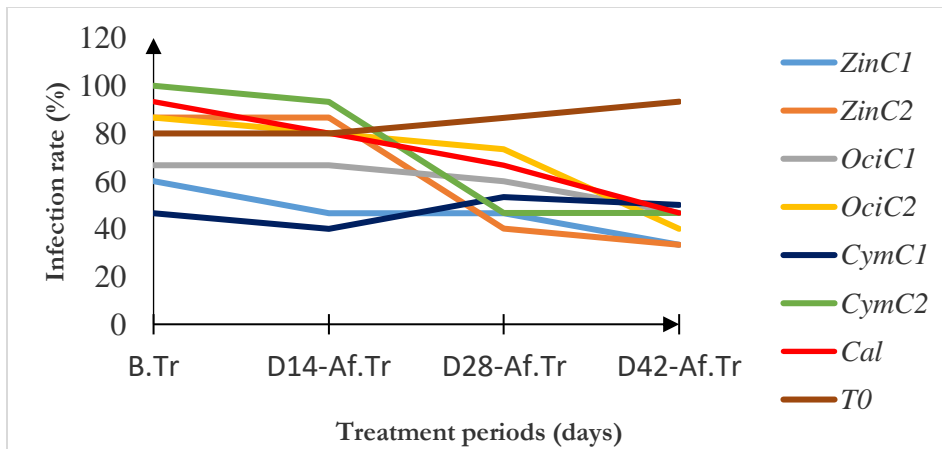

Figure 6: Incidence of orange rust disease in relation to time and treatments

B.Tr : Before treatment ; **D14-Af.Tr** : 14 Days After Treatment ; **D28-Af.Tr** : 28 Days After Treatment ; **D42-Af.Tr** : 42 Days After Treatment

4.4 Effect of biopesticides on orange rust disease severity as a function of time:

results showed that before treatment (B.Tr) with ZinC1, mean disease severity was 24%. (Figure 7) Fourteen (14) days after the first treatment, disease severity decreased to 13.33%. From 28 to 42 days after treatment, the mean of disease severity was constant at an estimated 12%. Plants treated with ZinC2 had a pre-treatment severity of 46.67%. At D14.Af.Tr, mean severity of 40% was recorded. A severity of 16% was obtained at D28.Af.Tr and D42.Af.Tr. Before treating plants with OciC1, a severity of 33.33% was obtained. Fourteen days after treatment (D14.Af.Tr), severity decreased to 25.33%. Severities of 20 and 17.33% respectively were observed at D28.Af.Tr and D42.Af.Tr. Disease severity observed in plants subsequently treated with OciC2 was 45.33%. A constant severity of 37.33% was obtained at D14.Af.Tr and D28.Af.Tr. In

addition, a 26.67% decrease in severity was noted. Plants treated with CymC1 had a pre-treatment severity of 28%. This severity decreased significantly, with a mean of 16% at D14.Af.Tr. However, an increase of severity was noted at D28.Af.Tr, with a value of 26.67%. Then, at D42.Af.Tr severity was 22%. Severities of 50 and 44% were noted before and at 14 days after treatment with CymC2, respectively. A progressive decrease in orange rust disease severity was observed after the other treatments, with a rate of 8% at D42.Af.Tr. Before treating plants with synthetic product, severity was 46.67%. At D14.Af.Tr a severity of 45.33% was observed. Severity decreased considerably from 37.33 to 29.33% respectively for D28.Af.Tr and D42.Af.Tr. Orange rust disease severity observed on untreated inoculated plants (T0) increased progressively, varying from 38.67 to 57.33% respectively from D28.Af.Tr to D42.Af.Tr.

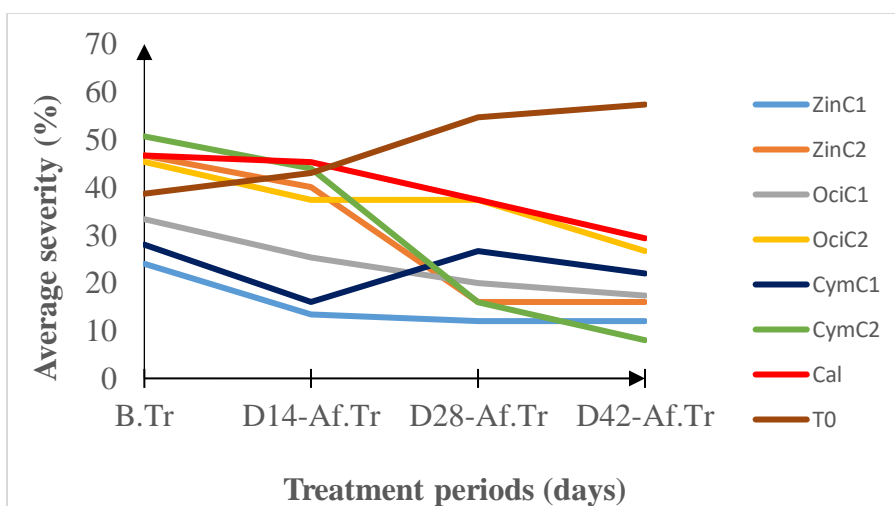

Figure 7: Evolution of orange rust disease severity in relation to time and treatments
B.Tr : Before treatment ; **D14-Af.Tr** : 14 days After Treatment ; **D28-Af.Tr** : 28 days After Treatment ; **D42-Af.Tr** : 42 days After Treatment

4.5 Effect of biopesticides on the incidence and severity of orange rust disease: infection rate of sugarcane orange rust disease incidence by biopesticides showed a significant difference between treatments at 5% level (table II). Untreated plants recorded a high infection rate of $85.0 \pm 5.0\%$. With the ZinC1, CymC1 and OciC1 treatments, the lowest infection rates were $41.67 \pm 7.96\%$, $48.33 \pm 7.96\%$ and $51.67 \pm 9.99\%$ respectively. For OciC2, CymC2 and Cal treatments, infection rates recorded were statistically identical, ranging

from 70.00 ± 5.00 to $71.67 \pm 9.98\%$. essential oils showed a lower severity than synthetic products. Plants treated with ZinC1 had the lowest disease severity, evaluated at $14.33 \pm 2.12\%$. However, those treated with ZinC2 and CymC2, recorded the highest severity, of 29.67 ± 4.47 and $29.67 \pm 5.65\%$ respectively. OciC1 and CymC1 treatments also showed statistically identical severities, estimated at 24.00 ± 2.56 and $23.67 \pm 2.72\%$ respectively. Untreated plants showed a severity of $48.42 \pm 4.01\%$ (Table 2).

Table 2: Incidence and severity of orange rust disease by product

Treatments	Codes	Infection rate (%)	Severity index (%)
Essential oils	ZinC1	$41,67 \pm 7,96c$	$14,33 \pm 2,12d$
	ZinC2	$61,67 \pm 6,74bc$	$29,67 \pm 4,47cd$
	OciC1	$51,67 \pm 9,99bc$	$24,00 \pm 2,56d$
	OciC2	$70,00 \pm 5,00ab$	$36,67 \pm 2,50bc$
	CymC1	$48,33 \pm 7,96c$	$23,67 \pm 2,72d$
	CymC2	$71,67 \pm 9,98ab$	$29,67 \pm 5,65cd$
Callicopper	Cal	$71,67 \pm 7,96ab$	$39,67 \pm 4,16b$
Negative control	T0	$85,00 \pm 5,00a$	$48,42 \pm 4,01a$
<i>P-value</i>		0,000002	0,000000

Means followed by the same letter in the same column do not present any statistical difference at the 5% threshold according to the Newman-Keuls test.

4.6 Reduction rate of orange rust disease incidence by product: Reduction rates varied from day to day. At the 14th post-treatment day (D14-Af.Tr), only treatment CymC1 was effective with a reduction rate of 50%, while negative reduction rates of -8.33 and -16.67% were noted for ZinC2 and CymC2 respectively. (figure 8). The maximum rate of disease incidence reduction, observed on day 28, was

53.84% for ZinC2. The lowest reduction rates were found with OciC2 and Callicopper, at 15.38 and 23.07% respectively. On day 42, when CymC1 was initiated, it showed a low reduction rate estimated at 46.42%. Treatments OciC1, CymC2 and Cal had reduction rates above the efficacy threshold, ranging from 50 to 64.28%. ZinC1 and ZinC2 treatments showed high reduction rates of 64.28%.

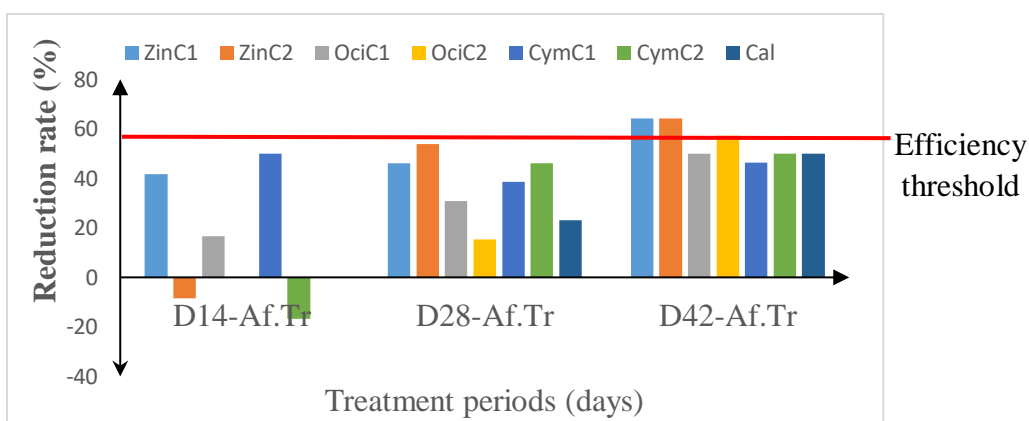

Figure 8: Rate of reduction in the incidence of orange rust disease as a function of treatments

D14-Ap.Tr: 14 days After Treatment ; **D28-Ap.Tr :** 28 days After Treatment ; **D42-Ap.Tr :** 42 days After Treatment

4.7 Rate of reduction in the severity of orange rust disease by products: All products reduced disease severity from day 14 after treatment. However, CymC2 showed the lowest severity (8%), while synthetic Callicuivre had the highest severity (29.33%). Untreated plants showed the highest severity (57.33%). Those treated with ZinC1 and ZinC2 recorded severities of 12% and 16% respectively on days 28 and 42. However, plants treated with CymC2 and Cal showed lower severity rates, ranging from 8% to 29.33% at 42 days post-treatment.

Essential oils of *Zingiber officinale* (ZnC1) and *Cymbopogon citratus* (CymC1) at 1000 ppm

showed the highest reduction rate of orange rust disease, with a value of 68.99% on the 14th day after treatment, while negative reduction rates were recorded for CymC2 and Cal treatments (Fig. 9). Products OciC2 and Cal showed a reduction rate below the efficacy threshold 28 days after treatment. ZinC1, ZinC2, OciC1 and CymC2 had the highest reduction rates, ranging from 63.41% to 78.05% respectively. CymC1 had a reduction rate slightly above the efficacy threshold, with a reduction of 51.22%. After treatment three, all products reached or exceeded efficacy. With the exception for the synthetic product (callicopper), which had a reduction rate of 48.83%, the OciC2 and

CymC2 treatments had reduction rates of 53.48 and 61.62% respectively. Highest reduction rates were observed in the ZinC1 79.07% and CymC2 86.04% treatments. The

ZinC2 and OciC1 treatments had intermediate reduction rates of 72.09 and 69.76% respectively (Fig. 9).

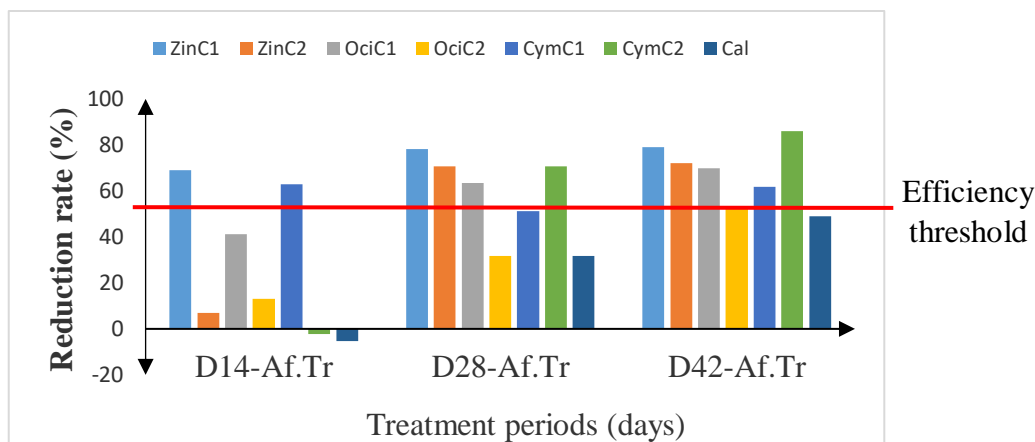

Figure 9: Rate of reduction in the severity of orange rust disease as a function of treatments **D14-Af.Tr**: 14 days After Treatment; **D28-Af.Tr** : 28 days After Treatment ; **D42-Af.Tr** : 42 days After Treatment

5 DISCUSSION

5.1 Pathogenicity of *Puccinia kuehnii* strains under semi-controlled conditions:

Evaluation of the pathogenicity of orange rust strains under semi-controlled conditions revealed pathogenic diversity. The first symptoms of orange rust disease, induced by strains 51bB and 381Z, were observed four months after inoculation (July). Plants infection at this time could be explained by their age, which plays an important role in the disease development. Our results are in line with those of Ovalle *et al.* (2009) and Raid *et al.* (2010), who reported that the severity of orange rust disease was greater in fields with plant aged from five to six months. They also stated that symptoms can be observed until plants have matured. Furthermore, the findings confirm those of Chapola *et al.* (2016), who reported an occurrence of orange rust disease four months after inoculation of the RB72454 and SP89-1115 varieties. An increase in disease severity was observed from month four (July) to seven (October). During this latter month, maximum disease intensity was recorded at

36.29±3.79% and 35.18±7.21% with strains 51bB and 381Z respectively. Disease development during this period could be explained by favourable conditions of high humidity and temperature. Indeed, this is a rainy season in Côte d'Ivoire, with low temperatures and high relative humidity. According to Araújo *et al.* (2013), development of sugarcane orange rust coincides with an increase in hours that are favourable for disease, thus increasing its occurrence. Infection of non-inoculated plants would be related to wind action, which facilitates disease spread, as well as to our presence during assessments. This was shown by the research of Ferrari *et al.* (2013), which reported that wind is responsible for spreading *Puccinia kuehnii* spores from region to region, and that these spores can easily adhere to clothing, hair, tools and footwear. Infante *et al.* (2009) also indicated that orange rust spores are spread mainly by wind and rainwater splash over short distances.

5.2 Antifungal effect of biopesticides in semi-controlled conditions: A decrease



in disease severity was observed with all treatments until evaluation was completed, with exception of CymC1 (*C. citratus* at 1000 ppm) where disease severity sometimes increased and other times decreased. In addition, except the synthetic product, all treatments were 50% effective at decreasing disease severity. Treatment CymC2 (*C. citratus* at 2000 ppm) showed the highest reduction rate and the lowest disease severity at the end of the trial, with values of 86.04 and 8% respectively. Biopesticides had a very good fungicidal effect on orange rust disease. The products' efficacy might be explained by the presence of one or more active ingredients with extremely effective antifungal properties, inhibiting *Puccinia kuehnii* growth and development. Essential oils' antifungal activity is directly related to their chemical composition. Research carried out by Janine d'Aquino *et al.* (2000), analysing essential oils' chemical composition, showed that *O. gratissimum* L. essential oil is mainly composed by eugenol, thymol, citral, ethyl cinnamate and linalool. Furthermore, the high levels of antifungal activity observed with a formulation based on *O. gratissimum* L. essential oil might be attributed exclusively to thymol. According to Dorman and Deans, 2000; Lopez-Malo *et al.* (2005), thymol is involved in inhibiting trehalase synthesis, an enzyme involved in glucose transformation in fungi. Cowan (1999) and Lopez-Malo *et al.* (2005) confirmed this statement, indicating that phenolic terpenes affect fungi by various mechanisms based, initially, on inactivation of fungal enzymes containing the SH group in their active site and, secondly, by binding

6 CONCLUSION

The objective of this study was to determine pathogenicity of *Puccinia kuehnii* strains in semi-controlled conditions. Strains 51bB and 381Z had statistically identical virulence. All treatments had an effect on the development of the sugarcane orange rust disease. Treatments using natural substances showed reduction rates above 50% threshold. *Zingiber*

to the amine and hydroxylamine groups of microbial membrane proteins, thereby altering permeability and causing intracellular compounds to be leaked. As for *C. citratus* essential oil, Guici and Boucetta (2017) noted that it has antifungal properties that enable it to treat certain mycoses radically. Also, Tiendrebeogo *et al.* (2017), indicated that essential oil has a repressive effect on the mycelial growth rate of *Pyricularia aoryzae* v. The efficacy of *Z. officinale* essential oil is thought to be caused by dry state of rhizomes used for its extraction. Indeed, differences between fresh and dried ginger extracts are found in chemical composition. According to Joy *et al.* (1998), the main constituent of fresh ginger is gingerol, and its concentration is lower in fresh ginger. As for dried ginger, its main constituent is shogaol, whose concentration increases in dried ginger extract and decreases in fresh ginger extracts. CymC2 and Cal (Callicopper at 5000 ppm) showed negative reduction rates in orange rust disease severity fourteen days after first treatment. This result can be explained by the high disease severity observed on these plants before treatment. *O. gratissimum* L, *C. citratus* and *Z. officinale* are found in the flora of Côte d'Ivoire. Essential oils extracted from these plants can therefore be used as an alternative to synthetic fungicides to control orange rust on sugarcane, and reduce negative effects associated with their use. Our results are in line with those of Kassi *et al.* (2014), who showed that essential oils could be effective and risk-free for users and environmental protection.

officinale essential oil treatments were effective at 1000 and 2000 ppm, after two applications. *Ocimum gratissimum* L and *Cymbopogon citratus* essential oil treatments were effective at 2000 ppm, with over 86.04% reduction by 42 days post-treatment. These biological treatments had no phytotoxic effect on treated plants. Three different biopesticides tested at



different doses were overall more effective than the synthetic product, callicopper. This means that these biopesticides can be

recommended for the control of orange rust on sugarcane in Côte d'Ivoire.

7 ACKNOWLEDGMENTS

We would like to acknowledge all those who contributed to the successful execution of this work. Special thanks to the Fond

d'Appui à la Recherche et à l'Innovation (FONARI) for funding this research, and to SUCRIVOIRE for sample collection.

8 BIBLIOGRAPHIC REFERENCES

- Ayres, P. G. 1978. Water relations of diseased plants. In: Kozlowski TT (ed) Water deficits and plant growth, vol 5. Academic Press, New-York. Pp1–60.
- Chapola, R. G., Hoffmann, H. P. and Massola, Jr. N. S. 2016. Reaction of sugarcane varieties to orange rust (*Puccinia kuehnii*) and methods for rapid identification of resistant genotypes. Trop. plant pathol. DOI [10.1007/s40858-016-0076-6](https://doi.org/10.1007/s40858-016-0076-6)
- Chaulagain, B., Small, I. M., Shine, J. M., Fraisse, C. W., Raid, R. N. and Rott, P. 2020. Weather-based predictive modeling of orange rust of sugarcane in Florida. Phytopathology 110:626–632. <https://doi.org/10.1094/PHTO-06-19-0211-R>
- Comstock, J. C., Sood, S. G. and Glynn, N. C. 2008. First report of *Puccinia kuehnii*, causal aente of orange rust of sugarcane, in the United States and western hemisphere. Plant Disease, v.92, n.1, P.175. DOI: [10.1094/PDIS-94-9-1170C](https://doi.org/10.1094/PDIS-94-9-1170C)
- Flores, R. C., Loyo, J. R., Ojeda, R. A. and Rangel, O. C. A. 2009. First report of orange rust of sugarcane caused by *Puccinia kuehnii* in Mexico, El Salvador, and Panama. Plant Disease, v.93, n.12, P.1347. DOI: [10.1094/PDIS-93-12-1347B](https://doi.org/10.1094/PDIS-93-12-1347B)
- Grimmer, M. K., John, F., M. and Paveley, N. D. 2012. Foliar pathogenesis and plant water relations: a review. J Exp Bot 63:4321–4331. <https://doi.org/10.1093/jxb/ers143>
- Hoy, J. W. 2008. Leaf rusts: old and new threats to sugarcane. Louisiana Agriculture, v.51, n.2, p.28-29.
- Huang, S. 2004. Progress of sugarcane disease research in China: Recent developments. Sugarcane Agriculture, v.6, n.4, P.261-265.
- Hubert, J., Jeandel, C., Costet, L., Hostachy, B., Dupuis, A. S., Coddeville, A., Barau, L., Ioos, R. 2019. First report of orange rust caused by *Puccinia kuehnii* on sugarcane on the Island of Reunion. Plant Dis 103:2962. [https://doi.org/ 10.1094/PDIS-04-19-0750-PDN](https://doi.org/10.1094/PDIS-04-19-0750-PDN)
- Infante, D., Martinez, B., Gonzalez, E. and Gonzalez, N. 2009. *Puccinia kuehnii* (Kruger) Butler y *Puccinia melanocephala* H. Sydow y P Sydow. en el cultivo de la caña de azúcar. Revista Protección Vegetal, v.24, n.1, P.22-28. http://scielo.sld.cu/scielo.php?pid=S1010-27522009000100003&script=sci_abstract&tlng=en
- Janine de Aquino, L. S., Xisto, S. P., Orionalda, de F. L. F., José, R. de P., Pedro, H. F., Lúcia, K. H. S., Aline de Aquino, L. and Maria, do R. R. S., 2005. Antifungal activity from *Ocimum gratissimum* L. towards *Cryptococcus neoformans*. Memorias do Instituto Oswaldo Cruz 100 (1): 55-58. <https://www.scielo.br/j/mioc/a/hDNwjRzscpkbctDtZVTBbHm/>



- Kranz J., 1988. Measuring plant disease. In: Kranz, J., Rotem, J. (eds). Experimental techniques in plant disease epidemiology. Springer, Berlin: 35 - 50. https://link.springer.com/chapter/10.1007/978-3-642-95534-1_4
- Mungur, H., Saumtally, S., Joomun, N. and Dookun-Saumtally, A. 2020. Presence of sugarcane orange rust in Mauritius. Sugar Tech 22: 671–674. <https://doi.org/10.1007/s12355-020-00818-x>
- Rott, P., Bousquet, J. F., Muller M. et Chatenet., M. 1997. La quarantaine de canne à sucre du Cirad à Montpellier. Agriculture et développement. N°13. 7p. https://agritrop.cirad.fr/389159/1/document_389159.pdf
- Rott, P., Sood, S., Comstock, J-C, Raid, R. N., Glynn, N. C., Gilbert, R. A. and Sandhu, H. S. 2017. Sugarcane orange rust. Agronomy Department. UF/IFAsS Extension. SS-AGR-378 <https://edis.ifas.ufl.edu/sc099>
- Sanjel, S., Chaulagain, B., Small, I. M., Comstock, J., Hincapie, M., Raid, R. N., Rott, P. 2019. Comparison of progress of brown rust and orange rust and conditions conducive for severe epidemic development during the sugarcane crop season in Florida. Plant Dis 103:825–831. <https://doi.org/10.1094/PDIS-05-18-0862-RE>
- Saumtally, A., Salem, V. T. R., Ahondokpê, B., Girard, J-C., Castlebury, L. A., Dixon, L., Glynn, N. C., Comstock, J. C. 2011. First report of orange rust of sugarcane caused by *Puccinia kuehnii* in Ivory Coast and Cameroon. Plant Disease, 95 (3): 357. <https://doi.org/10.1094/PDIS-09-10-0690>
- Sood S. G., Comstock J. C. et Glynn N. C. 2009. Leaf whorl inoculation method for screening sugarcane rust resistance. Plant Dis 93 (12) : 1335-1340. doi: [10.1094/PDIS-93-12-1335](https://doi.org/10.1094/PDIS-93-12-1335)